



LUXALON®

Stretch Metal

Luxalon® Stretch Metal offers architects contemporary design freedom. With these versatile materials it is easy to create an optical contrast to other surrounding materials. The wide choice of patterns, materials and colours gives every project a unique appearance.

HunterDouglas

CEILING



Stretch Metal

Striking visual effects

AESTHETIC DESIGN

Luxalon® Stretch Metal is a versatile architectural design material that creates striking visual effects. It is easy to create unique ceiling designs by variation in mesh types, mesh direction, lighting and colours.

Variation in ceiling design is easy if one keeps in mind that:

- The openness of the ceiling depends on the choice of mesh size and mesh pattern
- A change of mesh direction gives another incidence of light and therefore a different visual look
- Luminaries above the Stretch Metal ceiling gives lighting patterns and shadow effects

COLOURS AND FINISHES

There are a large quantity of RAL colours available with a short delivery time. In addition to these colours there are several special metallic colours and chrome in the program. The complete program of panels, grids, Bandraster profiles and edge profiles can be made in one colour for a smooth ceiling.

QUALITY

Our focus on quality control ensures the highest standard of production process, material, machinery and finished product. The superior durability of Hunter Douglas products translates into lower costs during the life cycle of the product due to longer life expectancy and lower maintenance costs. All our company processes are ISO 9001 certified.



No matter your style, our ceilings have the looks you love. Whatever your project's needs, our Tile Ceilings give you the freedom to think inside or outside the box.

CONTENT

Page

Tiles

4 - 5

Planks

6 - 7

PROVEN FIRE PROTECTION

All Luxalon® Stretch Metal Ceiling systems have earned a high reaction to fire classification according to EN 13501-1, in official fire tests at CSI, Bollate (Milaan) - an independent Italian fire research institute. For more information visit www.hunterdouglascontract.com

Innovative Products Make Innovative Projects



HunterDouglas

Mesh Types Tiles

Stretch Metal consists of metal sheet with diamond shaped holes. These holes are created without any waste of material, because the metal sheet is made with a tool that presses and stretches at the same time.

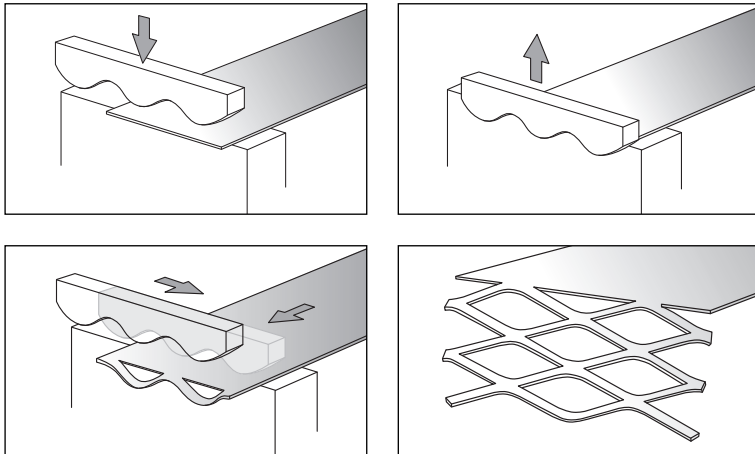

MESH TYPES

Standard

The standard mesh type is a square mesh (LS) or a diamond shaped mesh (LD) with a variation in openness of the mesh. The range starts with the smallest LS6/LD6 up to LS16. All mesh types are available in steel, with types LS8 and LS12 also available in aluminium.

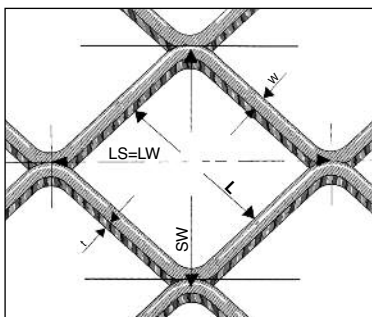

Key

- LS = LW
- LW = Long way of mesh
- SW = Short way of mesh
- W = Strand width
- t = Strand Thickness
- L = Inner size

Special

Several other mesh types are available on request depending on technical requirements and availability. Hexagonal mesh, Round mesh and Ornamental meshes are examples of the possibilities.

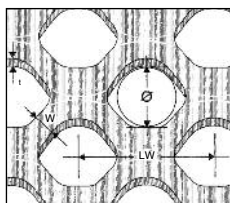
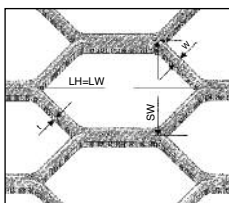

STANDARD MESH TYPES:

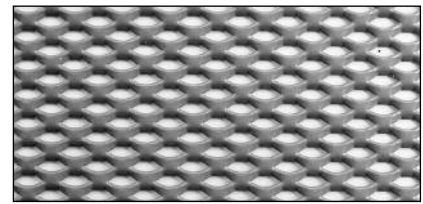

LD6 Fe open area 23%, thickness 1.7 mm

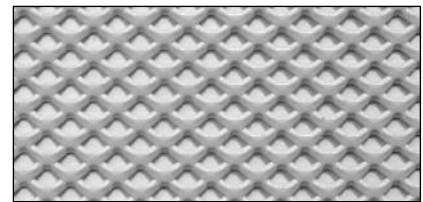

LS6 Fe open area 38%, thickness 1.7 mm

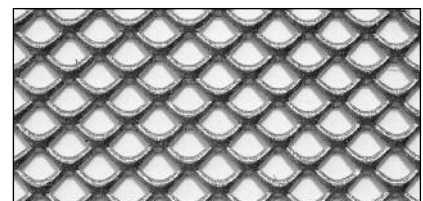

LS8 Fe + Al open area 62%, thickness 1.9 mm



LS10 Fe open area 68%, thickness 2.0 mm

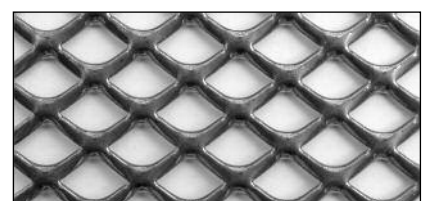

LS12 Fe + Al open area 72%, thickness 2.0 mm

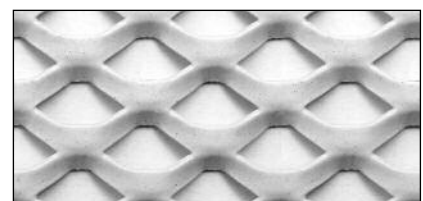

LS16 Fe open area 66%, thickness 2.0 mm

STANDARD SOLUTIONS

The standard Stretch Metal ceiling program consists of aluminium and steel tiles and planks.

TILES

The tiles program consists of modules 600 x 600 Lay-in, 625 x 625 Bandraaster and 1000 x 1000 Bandraaster solutions.

PLANKS

The planks program consists of a corridor, a Bandraaster and a C-grid solution. These planks are all made to measure with a maximum width of 500 mm and a maximum length of 2800 mm.

CUSTOM DESIGN

On special request several project solutions are possible. Custom sizes or shapes can be defined to make unique projects possible.

- **Special sized panels**

Custom made strengthened profiles make it possible to create wider and longer panels

- **Curved panels**

Custom made curved profiles create unique concave, convex and undulating shapes

ACOUSTICS

Using acoustic pads on top of the Stretch Metal panels offers exceptional acoustic performance. The thickness of the pads can be chosen depending on the required acoustical values. The acoustic absorption value can reach α_w 1 with an acoustical pad of 85 mm.

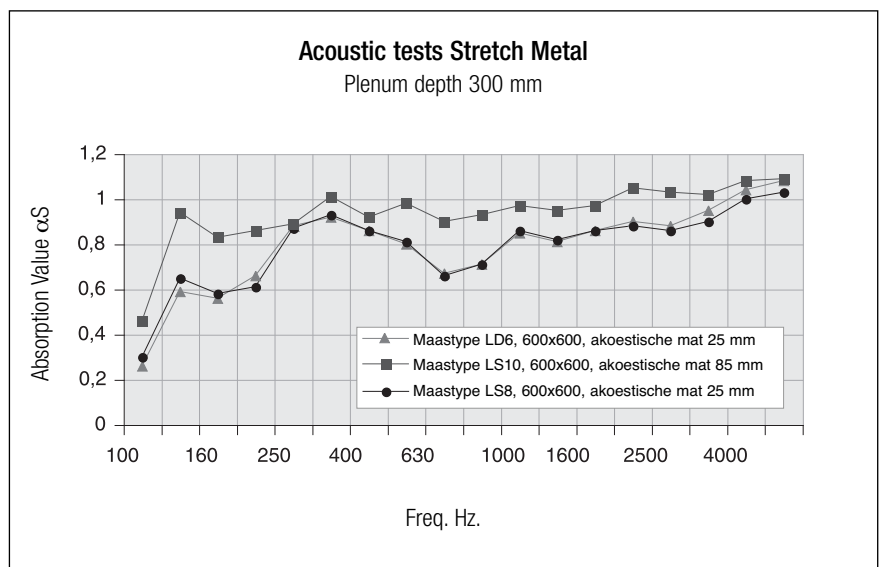

Tiles

SHORT SYSTEM DESCRIPTION

Luxalon® Lay-In tiles are designed to be installed on conventional T-grid systems (T-Bar sizes 15 and 24 mm) or Bandraster system (50-100 mm). By pushing the tile upwards it is easy to gain access to the plenum without the use of special tools.

PRACTICAL APPLICATION AREAS

Luxalon® Stretch Metal tiles are ideal for solutions where either a high level of acoustic absorption is required or where visual and physical transparency of the ceiling is requested. The systems are also ideal for solutions where regular access into the plenum is required.

TRANSPARENCY

The tiles can be made from various mesh types. This results in different optical effects if the natural or artificial light comes from the plenum. The physical transparency can also be used for smoke extraction and sprinkler operation in case of fire.

PLENUM ACCESSIBILITY

Because each tile has flanges that simply rest on the T-Grid profiles, the access to the plenum is achieved by lifting the tile up into the area above the ceiling.

ACOUSTICS

Excellent sound absorption is obtained with the different mesh types in combination with acoustic pads. Absorption co-efficients of up to α_w 1 are achievable.

MESH TYPES

Tiles are available in a standard square mesh LS or diamond shaped mesh LD with differences in open area. Special meshes are available on request.

SYSTEM OVERVIEW STRETCH METAL LAY-IN TILES

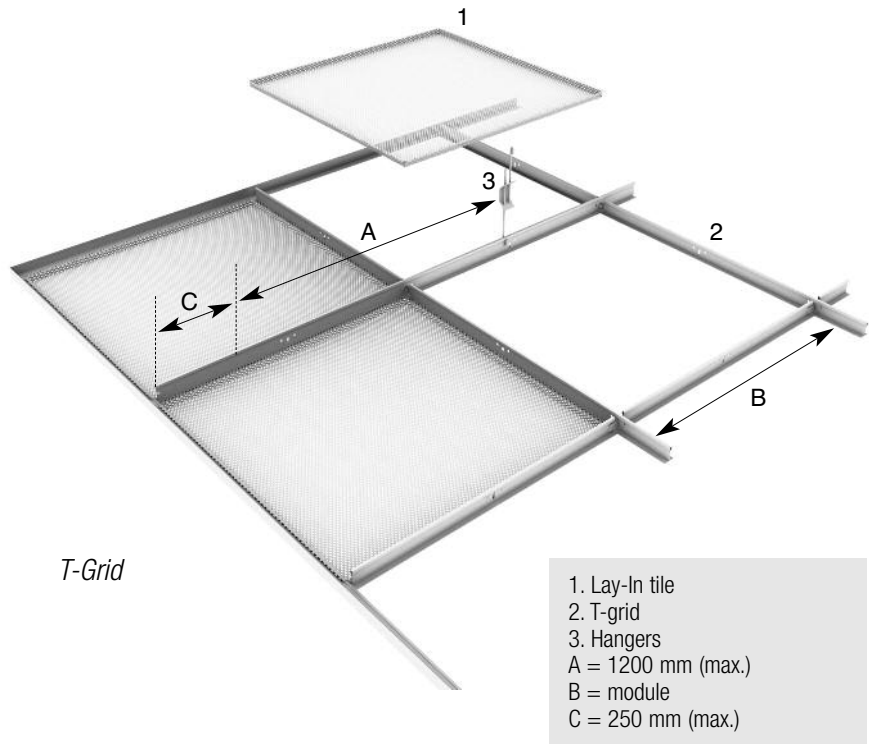

T-Grid

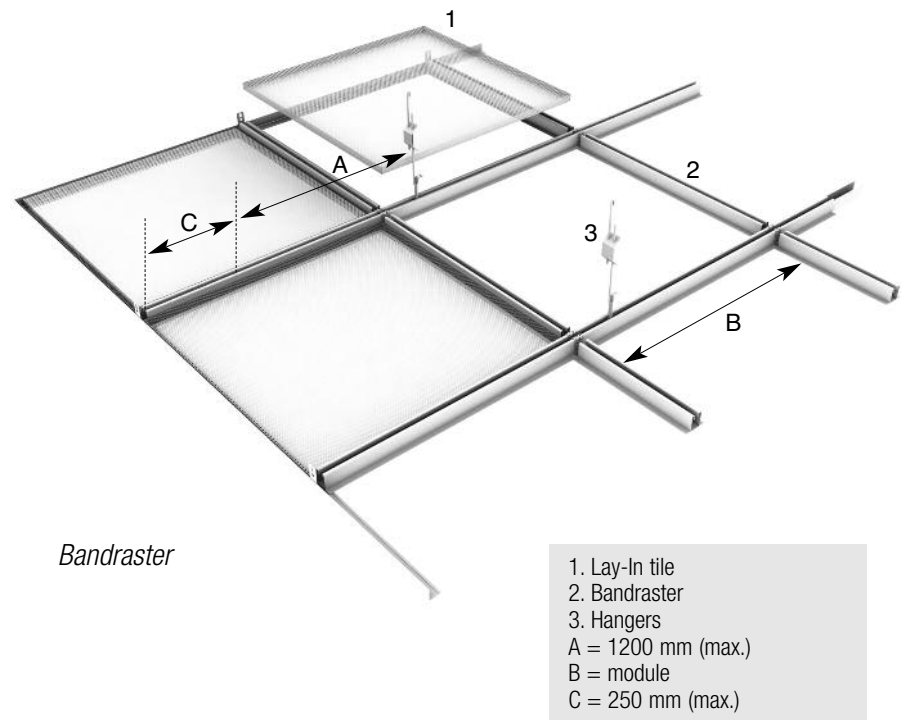

Bandraster

Tiles

DIMENSIONS

Lay-In Tiles 15/10; 15 mm Grid,
10 mm Reveal

Module in mm

600 x 600

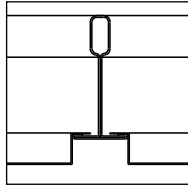

Lay-In Tiles 24/15; 24 mm Grid,
15 mm Reveal

Module in mm

600 x 600

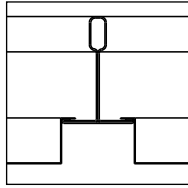

Lay-In Tiles 24/0; 24 mm Grid,
0 mm Reveal

Module in mm

600 x 600

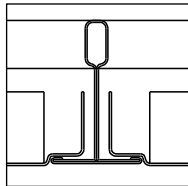

Lay-In Tiles; 50 mm Bandraster,
0 mm Reveal

Module in mm

625 x 625

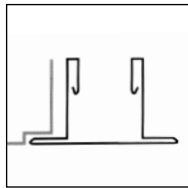

Lay-In Tiles 15/10; 15 mm channel Grid

Module in mm

600 x 600

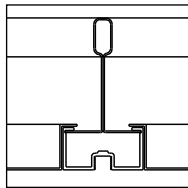

*(T-profile with integrated fixing
possibility for partitions)*

MATERIAL REQUIREMENT PER M²

Components	Unit	600 x 600
Luxalon® Stretch Metal	pcs.	2.78
Grid profile	lm	3.34
Suspension	pcs	0.69

Lay-In Tiles; 100 mm Bandraster

Module in mm

1000 x 1000

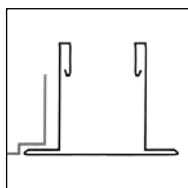

(Only steel)

MATERIAL SPECIFICATIONS

BASE MATERIAL

Luxalon® Lay-In tiles module
600 mm and 625 mm are available in
steel and aluminium. Luxalon® Lay-In tiles
module 1000 mm are available in steel.

COATING

Stretch Metal tiles are all powder coated
materials. Durable powder coatings for
exterior use are optionally available.

COLOUR RANGE

The standard colour range consists of
225 RAL and NCS colours, including
chrome. Other special colours are
available on request.

FIRE BEHAVIOUR

Suspended Luxalon® metal ceilings are
classified incombustible, and will therefore
not contribute to fires. When ceilings need
to protect the structural integrity of a
building, Luxalon® ceilings offer a wide
range of practical solutions with regards
to fire resistance and fire stability. Further
information is available on request.

Planks

SHORT SYSTEM DESCRIPTION

Luxalon® steel planks are designed to be installed on conventional C-Grid systems, Bandraster and wall profiles.

The planks can be lifted and easily removed without the aid of tools. The steel panels are recyclable, lightweight and strong.

PRACTICAL APPLICATION AREAS

Luxalon® Stretch Metal planks are ideal for solutions where either a high level of acoustic absorption is required or where visual and physical transparency of the ceiling is requested. The systems are also ideal for solutions where regular access into the plenum is required.

TRANSPARENCY

The planks can be made from various mesh types. This results in different optical effects if the natural or artificial light comes from the plenum. The physical transparency can also be used for smoke extraction and sprinkler operation in case of fire.

ACOUSTIC PERFORMANCE

Excellent sound absorption is obtained with the different mesh types in combination with acoustic pads. Absorption co-efficients of up to $w 1$ are achievable.

MESH TYPES

Planks are available in standard mesh types LD6/LS6, LS8 or LS12 with differences in open area. Special meshes are available on request.

SYSTEM OVERVIEW STRETCH METAL PLANKS

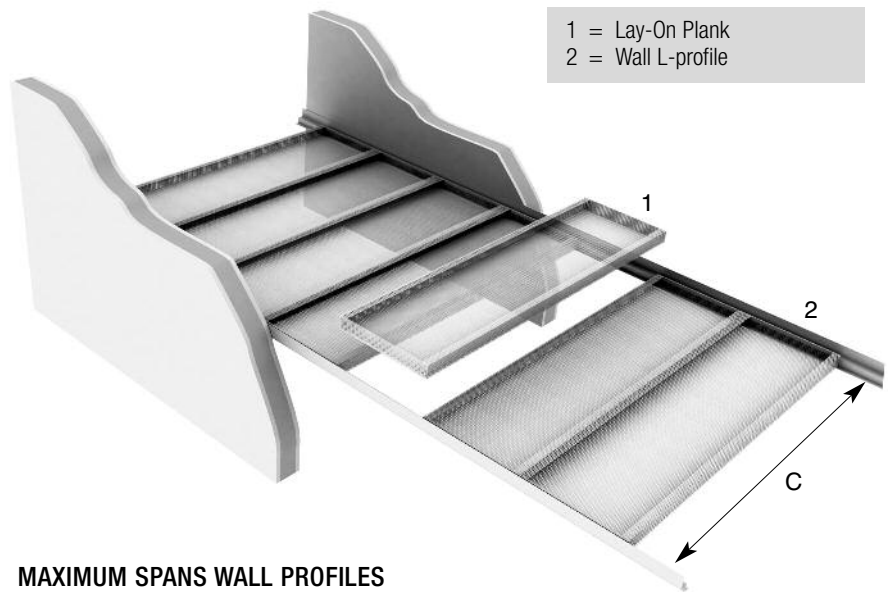

- 1 = Lay-On Plank
- 2 = Wall L-profile

MAXIMUM SPANS WALL PROFILES

Panel type	Panel Span C
Type-I Stretch Metal	1500
Type-II Stretch Metal + profile	2400
Type-III Stretch Metal + C-profile	2800

- 1 = Lay-On Plank
- 2 = Bandraster profile
- 3 = Suspension

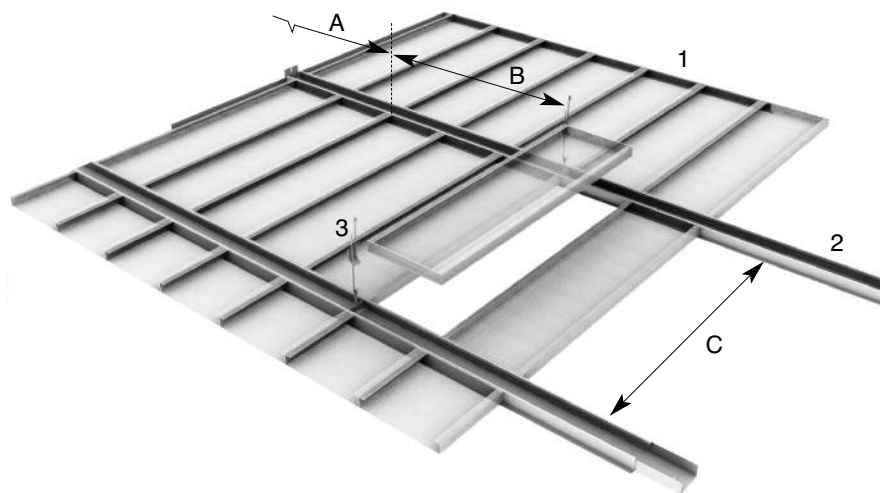

MAXIMUM SPANS BANDRASTER

Panel type	Profile Span		Panel Span C
	A	B	
Type-I Stretch Metal	on request	on request	1500
Type-II Stretch Metal	on request	on request	2400
Type-III Stretch Metal	on request	on request	2800

LAY-ON PLANK SOLUTIONS

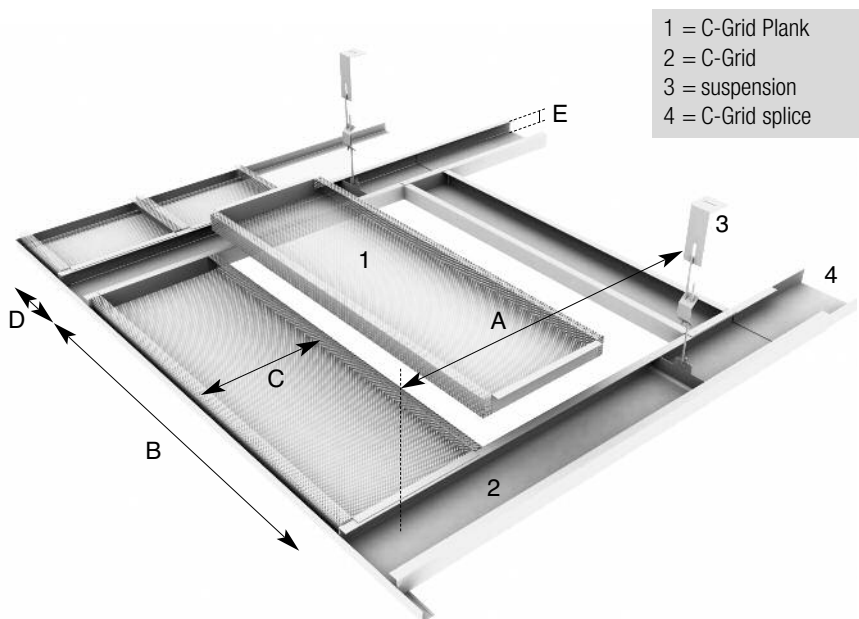
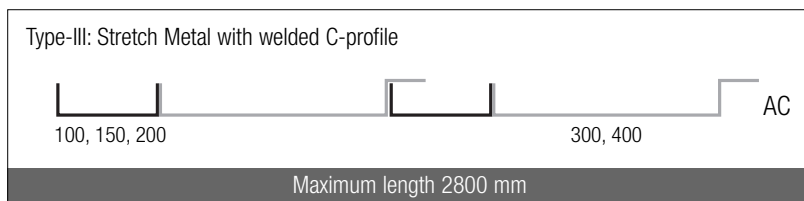
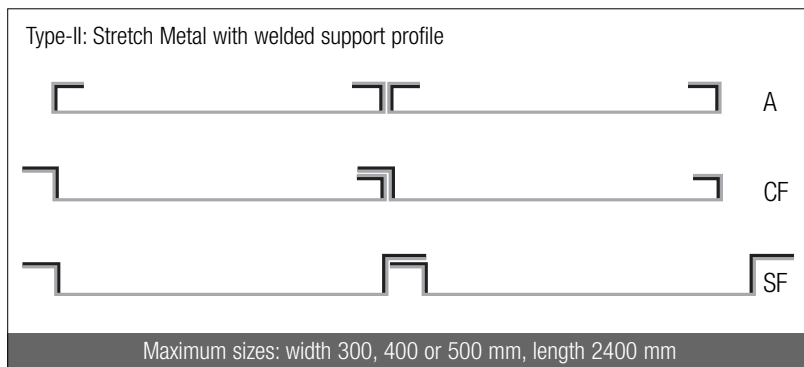
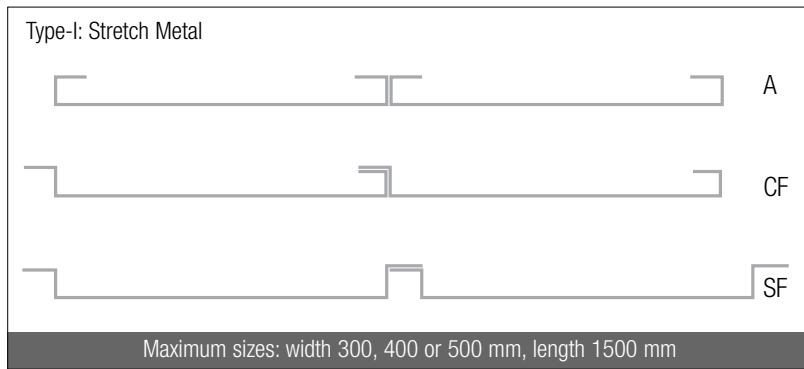

DIMENSIONS *C-Grid*

Item type	Plank width C	C-Grid width D	C-Grid + plank height E
Steel	300 of 400	120, 150 of 200	40

MATERIAL SPECIFICATIONS

BASE MATERIAL

Luxalon® Stretch Metal planks are available in steel. The Stretch Metal plank (type-I) can be strengthened with a welded support profile inside (type-II) or alongside a welded C-profile (type-III) for larger planks.

COATING

Stretch Metal planks are all powder coated materials. Durable powder coatings for exterior use are optional.

COLOUR RANGE

The standard colour range consists of 225 RAL and NCS colours, including chrome. Other special colours are available on request.

FIRE BEHAVIOUR

Suspended Luxalon® metal ceilings are classified incombustible, and will therefore not contribute to fires. When ceilings need to protect the structural integrity of a building, Luxalon® ceilings offer a wide range of practical solutions with regards to fire resistance and fire stability.

Further information and special executions on request.

MAXIMUM SPANS *C-Grid*

Panel type	Profile Span A	Panel Span B
Steel	1250	1300

HUNTER DOUGLAS ARCHITECTURAL PRODUCTS

In the last 50 years, we've been fortunate enough to help turn countless innovative sketches into innovative buildings.



Architects, designers, investors and contractors from around the world have taken advantage of Hunter Douglas' unmatched product development, service and support. Chances are, you've seen more of Hunter Douglas than you think.

With major operation centres in Europe, North America, Latin America, Asia and Australia, we've contributed to thousands of high-profile projects, from retail and commercial facilities to major transit centres and government buildings.

Not only are the world's architects and designers our partners, they're our inspiration. They continue to raise the bar for excellence. We create products that help bring their visions to life: Window Coverings, Ceilings, Sun Control Systems and Façades.



Promoting sustainable
forest management
www.pefc.org



Hunter Douglas products and solutions are designed to improve indoor environmental quality and conserve energy, supporting built environments that are comfortable, healthy, productive, and sustainable.



Our paint and aluminium melting processes are considered to be one of the industry standards in terms of clean production processes. All aluminium products are 100% recyclable at the end of their lifecycle.

ARCHITECTURAL SERVICES

We support our business partners with a wide range of technical consulting and support services for architects, developers and installers. We assist architects and developers with recommendations regarding materials, shapes and dimensions and colours and finishes. We also help creating design proposals, visualisations and mounting drawings. Our services to installers range from providing detailed installation drawings and instructions to training installers and advising on the building site.



HunterDouglas

CEILING



HUNTER DOUGLAS is a publicly traded company with activities in more than 100 countries with over 150 companies.

The origin of our company goes back to 1919, in Düsseldorf, Germany. Throughout our history, we have introduced innovations that have shaped the industry, from the invention of the continuous aluminium caster, to the creation of the first aluminium Venetian Blinds, to the development of the latest high-quality building products.

Today we employ more than 16,500 people in our companies with major operation centres in Europe, North America, Latin America, Asia and Australia.

Innovative Products Make Innovative Projects

© Registered trademark - a HunterDouglas® product Pats. & Pats. Pend. - Technical data subject to change without notice. © Copyright Hunter Douglas 2014. No rights can be derived from copy, text pertaining to illustrations or samples. Subject to changes in materials, parts, compositions, designs, versions, colours etc., even without notice.

Learn More

- Contact our Sales office
- www.hunterdouglascontract.com

Wide Panel

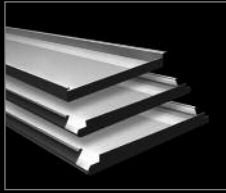

Linear

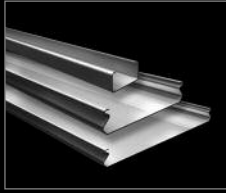

Screen



Tiles
XL panel

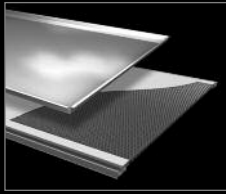

Cell
Stretch metal

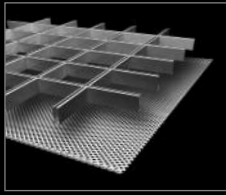

Curved

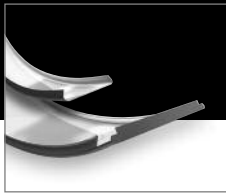

Exterior

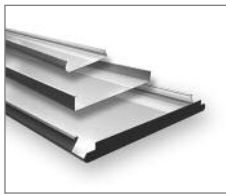

- Belgium
- Bulgaria
- Croatia / Slovenia
- Czechia
- Denmark
- France
- Germany
- Greece
- Hungary
- Italy
- The Netherlands
- Norway
- Poland
- Portugal
- Romania
- Russia
- Serbia
- Slovakia
- Spain
- Sweden
- Switzerland
- Turkey
- United Kingdom
- Africa
- Middle East
- Asia
- Australia
- Latin America
- North America

HUNTER DOUGLAS EUROPE B.V.
 2, Piekstraat
 P.O. Box 5072 - 3008 AB Rotterdam
 The Netherlands
 Tel. +31 (0)10 - 486 99 11
 Fax +31 (0)10 - 484 79 10
www.hunterdouglascontract.com

HunterDouglas